



CONTAINER SOLUTIONS

Pellet and Woodchip

EVO WORLD presents its new range of containerised solutions
With outputs ranging from 25 to 500kW and flexible layouts
suitable for both wood pellet and chip

Turnkey solutions, ready to “plug and play”

The containerised biomass boiler solutions are the best solution for customers who want a quality plug and play heating installation with guarantees of 10 years for their projects.

With a range of power from 25 to 500kW pellet or woodchip, our technical department will find the most suitable configuration for each project.

Turnkey solutions ready to plug and play.

The containerised solutions from EVOWORLD include:

- » EVOWORLD boiler with 10 years guarantee
- » Door for maintenance access and external window
- » Fuel storage with DELOX exact level monitoring
- » Internal walls lined with plywood to avoid condensation
- » Wood skin finished for exterior walls with a 15 years warranty
- » 2 x Storz 110A for the filling of the storage incl. impact protection mat
- » Sliding roof for woodchip containers
- » Buffer tank with 100mm insulation incl. expansion vessel
- » Pre-plumbed and insulated
- » Twin walled chimney
- » Return pump and mixer
- » Connections for energy distribution
- » Heat meter
- » Remote control (GSM/internet)
- » Ash extraction system 60L/200L

Dimensions

	External			Internal		
	<i>Length</i>	<i>Wide</i>	<i>Height</i>	<i>Length</i>	<i>Wide</i>	<i>Height</i>
ISO 20'	6.058	2.438	2.591	5.898	2.350	2.390
ISO 20' HC	6.058	2.438	2.896	5.898	2.350	2.680
ISO 40'	12.192	2.438	2.591	12.032	2.350	2.390
ISO 40' HC	12.192	2.438	2.896	12.032	2.350	2.680



Pellet Options - 20' Containers

TYPE	BOILER	PERFORMANCE	CONTAINER	BUFFER	SILO	SILO NET CAPACITY	
		KW				SIZE	(L)
PELLET	P200	199	20'	1500	INTERNAL	13,2	8,6
42.200.00.1000							
PELLET	P150	150	20'	1500	INTERNAL	13,2	8,6
42.150.00.1000							
PELLET	P120	120	20'	1500	INTERNAL	13,2	8,6
42.120.00.1000							
PELLET	P100	100	20'	1500	INTERNAL	13,2	8,6
42.100.00.1000							
PELLET	P50	50	20'	1500	INTERNAL	13,2	8,6
42.050.00.1000							

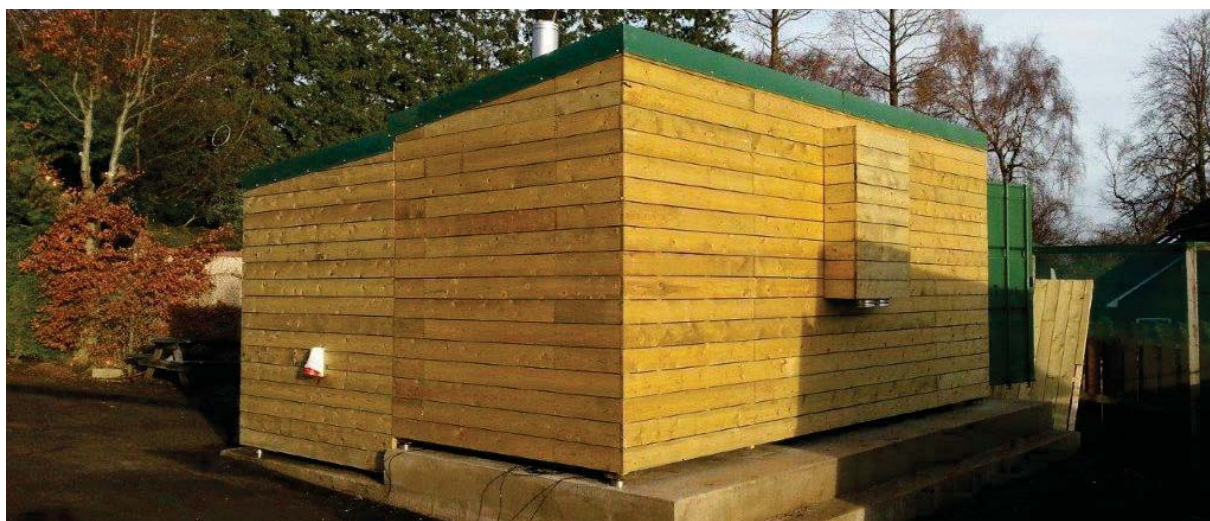

Pellet Options - 40' Containers

TYPE	BOILER	PERFORMANCE	CONTAINER	BUFFER	SILO	SILO NET CAPACITY	
ART. NR		KW	SIZE	(L)	TYPE	M3	TON
PELLET	P200	199	40'	3000	INTERNAL	30,4	19,7
44.200.00.1000							
PELLET	P150	150	40'	3000	INTERNAL	30,4	19,7
44.150.00.1000							
PELLET	P120	120	40'	3000	INTERNAL	30,4	19,7
44.120.00.1000							
PELLET	P100	100	40'	3000	INTERNAL	30,4	19,7
44.100.00.1000							

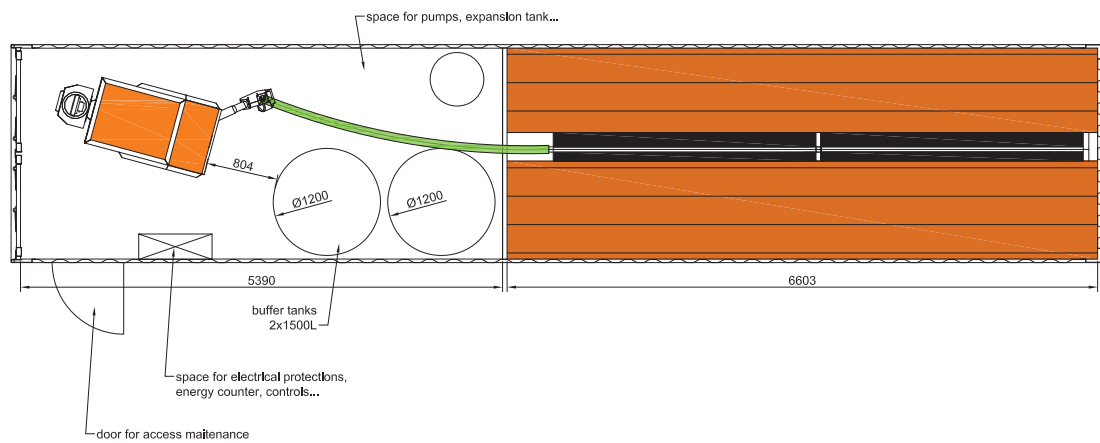

Woodchip Options - 40' / 20' Containers

TYPE	BOILER	PERFORMANCE	CONTAINER	BUFFER	SILO	SILO NET CAPACITY	
ART. NR		KW	SIZE	(L)	TYPE	M3	TON
WOODCHIP 24.200.00.1000	HS200	199	40'	2500	INTERNAL	38,5	12,6
WOODCHIP 24.150.00.1000	HS150	150	40'	2500	INTERNAL	38,5	12,6
WOODCHIP 24.120.00.1000	HS120	120	40'	2500	INTERNAL	38,5	12,6
WOODCHIP 24.100.00.1000	HS100	100	40'	2500	INTERNAL	38,5	12,6
WOODCHIP 22.050.00.1000	HS50	50	20'	1000	INTERNAL	15,5	5,1

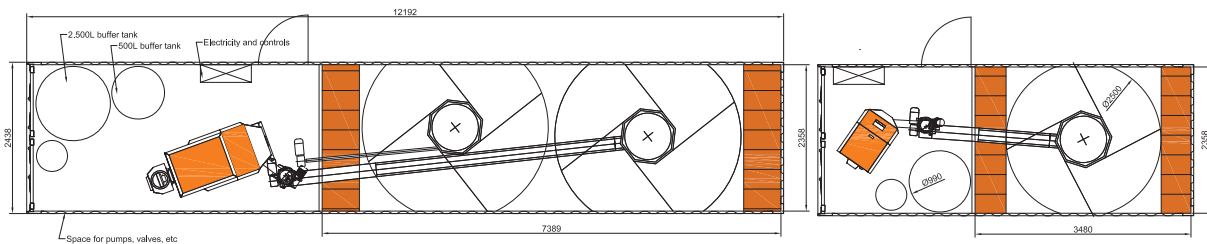

Pellet Options - 20' Container with External Silo

TYPE	BOILER	PERFORMANCE	CONTAINER	BUFFER	SILO	SILO NET CAPACITY	
ART. NR		KW	SIZE	(L)	TYPE	M3	TON
PELLET	P200	199	20' HC	6000	EXTERNAL	-	-
43.200.00.1000					(NOT INCLUDED)		
PELLET	P100	100	20'	3000	EXTERNAL	-	-
42.100.00.1000					(NOT INCLUDED)		

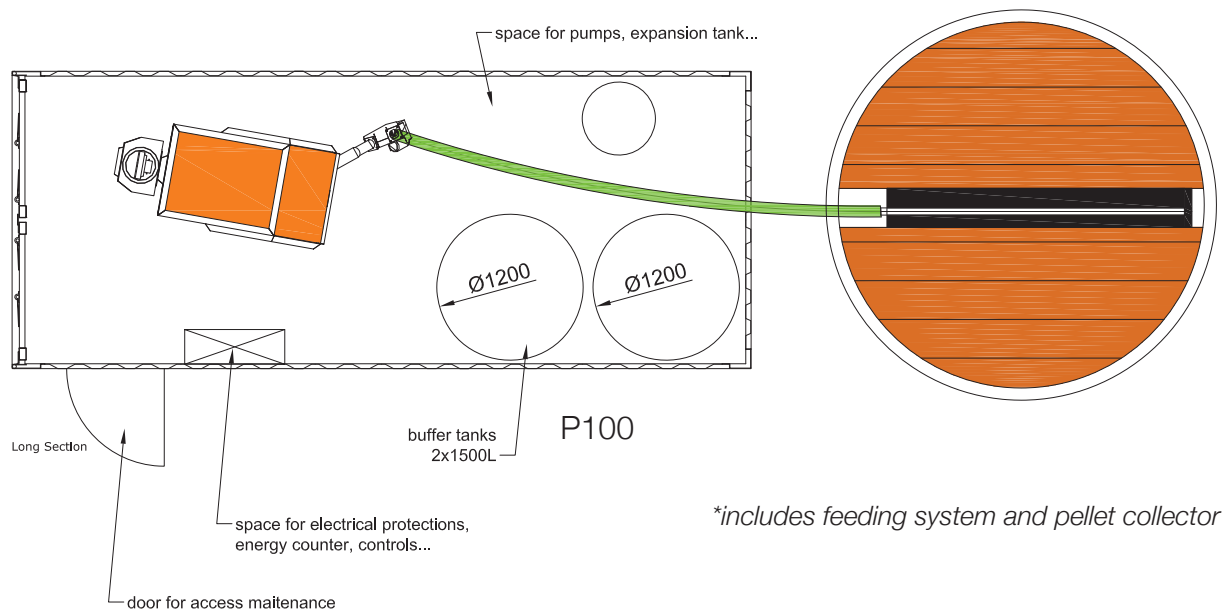

Woodchip Options - 20' Container with External Silo

TYPE	BOILER	PERFORMANCE	CONTAINER	BUFFER	SILO	SILO NET CAPACITY	
ART. NR		KW	SIZE	(L)	TYPE	M3	TON
WOODCHIP	HS200	199	20' HC	6000	EXTERNAL	-	-
43.200.00.1000					(NOT INCLUDED)		
WOODCHIP	HS100	100	20'	3000	EXTERNAL	-	-
42.100.00.1000					(NOT INCLUDED)		

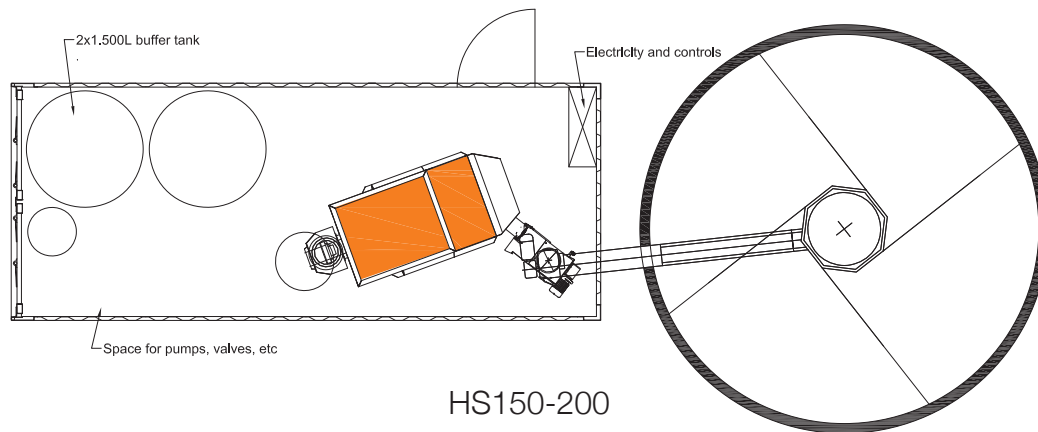

**includes feeding system and agitator*



EVOWORLD SPAIN, SL
 C/ Roquetes, nave 91
 08187 Sta. Eulàlia de Ronçana
 Barcelona (Spain)
 +34 938 406 488
 esp@evo-world.com

EVOWORLD GmbH
 Seeleitenstr. 20
 5120 St. Pantaleon
 Austria
 office@evo-world.com

EvoWorld UK
 Unit A4 Stanlaw
 Abbey Business Centre
 Dover Drive
 Ellesmere Port
 Cheshire
 uk@evo-world.com

EVOWORLD Inc.
 2800 7th Ave
 TROY, NY 12180
 NEW YORK
 usa@evo-world.com

www.evo-world.com

